

A Machine That Learns

Concerning Machina docilis, descendant of Machina speculatrix, the small imitation of life that was described in the May, 1950, issue of this magazine

by W. Grey Walter

THIS ARTICLE is a sequel to one published here last year which described experiments with a simple little machine designed to mimic certain elementary features of animal behavior ("An Imitation of Life," SCIENTIFIC AMERICAN, May, 1950). Consisting only of two vacuum tubes, two motors, a photoelectric cell and a touch contact, all enclosed in a tortoise-shaped shell, the model was a species of artificial creature which could explore its surroundings and seek out favorable conditions. It was named *Machina speculatrix*. Although it possessed just three simple characteristics—the properties of being attracted to moderate light and repelled by bright light or by material obstacles—*M. speculatrix* displayed complex and unpredictable habits of behavior, resembling in some ways the random variability, or "free will," of an animal's responses to stimuli. But its responses were in no way modified by experience; in other words, it lacked the power to learn.

We have gone on from that early model to the design of a more advanced mechanical creature which does possess the ability to learn. The present report will describe this new creature, named *M. docilis* from the Latin word meaning teachable.

The mechanism of learning is of course one of the most enthralling and baffling mysteries in the field of biology. In its simplest experimental form modification of behavior by experience is often called "conditioning," a term suggested by the Russian physiologist I. P. Pavlov, whose original experiments on "conditioned reflexes" brought the study of higher nervous function into the realm of brain physiology. The basic event in this form of learning is that an unrelated stimulus, when repeatedly coupled with one that evokes a certain response, comes to acquire the meaning of the original stimulus. In the classical experiments on animals the activity used as the basis for conditioning was a simple reflex—the flow of saliva when food enters the mouth, or the withdrawal of a leg when a painful stimulus is given to the foot. The food or the pain is called the uncon-

ditioned, or specific, stimulus. The conditioned, or neutral, stimulus to which the animal is trained to respond with the same behavior can be any event to which the animal is sensitive: a light, a sound, a touch—anything at all. If, for example, a bell is rung on 10 or 20 occasions just as food is offered, the flow of saliva, which originally occurred only at the sight of the food, eventually is conditioned to begin as soon as the bell is rung. After about 20 more repetitions the bell alone, without the presence of food, evokes almost as copious a flow of saliva as does the food itself. One may say that the bell comes to "mean" food.

SUCH learning is of course perfectly familiar in ourselves and is the basis of all animal training. Indeed it has been argued that all learning is based on conditioning, for any bodily function can be made the basis of a conditioned reflex, and one conditioned reflex can be built on another. Even quite unconscious changes, such as quickening of the pulse, dilation of the pupils, a rise in blood sugar or a fall in temperature, can be "conditioned" to some previously neutral stimulus by mere repetition. In this way it is possible to obtain control over functions originally quite involuntary. A man can "learn" to slow his pulse, flush, go pale, secrete sugar in his urine and so forth by a process of simple conditioning. This process may be conscious and deliberate, and such training accounts for the feats of Yogi fakirs. It may also be unconscious and even undesired by the subject, sometimes producing "psychosomatic" disorders, in which symptoms of bodily disease are attributable to nervous strain or conflict.

In spite of the vast mass of empirical information collected by Pavlov and his pupils, we still do not understand the process whereby the neutral stimulus acquires the meaning of the original one. But it is clear that one of the principal requirements for this associative learning is a complex mechanism of memory, capable not only of storing the traces of the two series of events but also of providing the information that the coinci-

dence between the two is greater than would be expected by chance. The creation of such a memory mechanism was the problem to which we addressed ourselves in designing *M. docilis*.

Our earlier model, *M. speculatrix*, had a very elementary form of memory. In order to get around an obstacle it encountered, the model had to remember it long enough to get well away from the hindrance before resuming its journey to the attracting light. Even among living creatures such a memory is not universal; the absence or brevity of this memory accounts for the tireless and ineffective buzzing of a fly on a windowpane. *M. speculatrix's* elementary memory works as follows: When the model touches an obstacle, the contact closes a circuit which converts its two-stage amplifier into an oscillator of the type known as a "multivibrator." The oscillations thus generated make the model stop, turn, withdraw, and go forward, and these maneuvers are repeated until the contact is opened by clearance of the obstacle. It is a characteristic of this simple circuit that while it is oscillating it cannot amplify, so the model is blind to the attracting light while circumventing a material difficulty. Furthermore, even after the touch contact is opened, one more oscillatory discharge takes place, and this ensures that the model moves well away from the obstacle before regaining its vision. The after-discharge in the oscillatory circuit is an example of the most elementary form of memory trace, in which the internal effect of a stimulus outlasts its external duration. Such an after-discharge is common in the reflex activity of the spinal cord of animals, and the more complex the reflex, the longer the after-discharge is likely to last. When you step on a tack, your leg is withdrawn by reflex action, but the withdrawal continues after your foot has left the tack, so that when you straighten your leg again it does not come down on the same place.

ON first analysis the problem of transforming *M. speculatrix* into an educable species seemed quite simple.

Its essentials are illustrated by the upper of the two diagrams at the lower left-hand side of the next page. In *M. speculatrix* we had a reflex mechanism with three elements: a specific stimulus S_s (a light or touch), which produced a specific effect E_s (the operation of the motor relays) by way of a transmission system T_1 (the two-stage amplifier). To introduce the factor of conditioning, this mechanism must be linked with a second activated by a neutral stimulus which does not initially produce the effect E_s . The second arrangement would consist of the neutral stimulus S_n and a transmission system T_2 . (It might produce a specific effect of its own, E_{s_2} , but with this we are not at the moment concerned.) T_1 must be linked with T_2 in such a way that the former comes to respond to the neutral stimulus with its normal effect E_s , as if S_n were in fact S_s . This means that there must be a "learning box" of some kind between T_1 and T_2 . The question is: What are we to put into the learning box (L)?

Obviously it must contain an apparatus which will receive signals from both T_1 and T_2 and combine them in such a manner that after S_s and S_n have occurred together more often than they would by chance, S_n can find its way through the learning box and have the

effect E_s . We experimented with some simple electronic circuits suggested by these requirements, but the first trials were disappointing. We soon realized that a more detailed analysis of the learning process would be necessary. It was clear that the statistical relation between S_s and S_n would have to be assessed before we could determine how to establish an association between them. That is, circuits must be provided to deal with any particular S_s and S_n in such a way that only a significant degree of coincidence between them would be registered. For example, an animal being trained to expect food when a bell is rung and food is offered entirely at random, there is no basis for supposing the two to be in any way related.

It took some time to appreciate the number and complexity of the operations involved in establishing a connection between different stimuli to achieve a conditioned response. Eventually it was found that no fewer than seven distinct operations must be performed. They are:

1. The beginning of the specific stimulus must be sharply differentiated from the absence of the stimulus. That is, it is the change that is important, e.g., the transition from no food to food in the

case of an animal, rather than the duration of the stimulus.

2. On the other hand, the impact of the neutral stimulus must be extended in time. This is because it may occur some while before the specific stimulus and must therefore be "remembered" long enough for its significance to be noticed.

3. The series of clipped S_s and stretched S_n must be mixed in such a way that their areas of coincidence are appreciated.

4. The coincident areas must all be summated, or integrated, to form a consolidated stimulus.

5. When the sum of all the areas of coincidence reaches a value greater than would ever be obtained by chance, the memory process is activated. This activation is in the nature of a trigger process—a single event, analogous to a flash of insight into a contingency previously ignored.

6. Once the existence of a significant degree of coincidence between S_s and S_n has been registered, it is preserved in the memory for some time and fades away gradually. In the *M. docilis* model the memory takes the form of a damped oscillation, but it could well be any mechanical, chemical or electrical process in which stored energy is slowly released, as in the escapement of a watch. It is

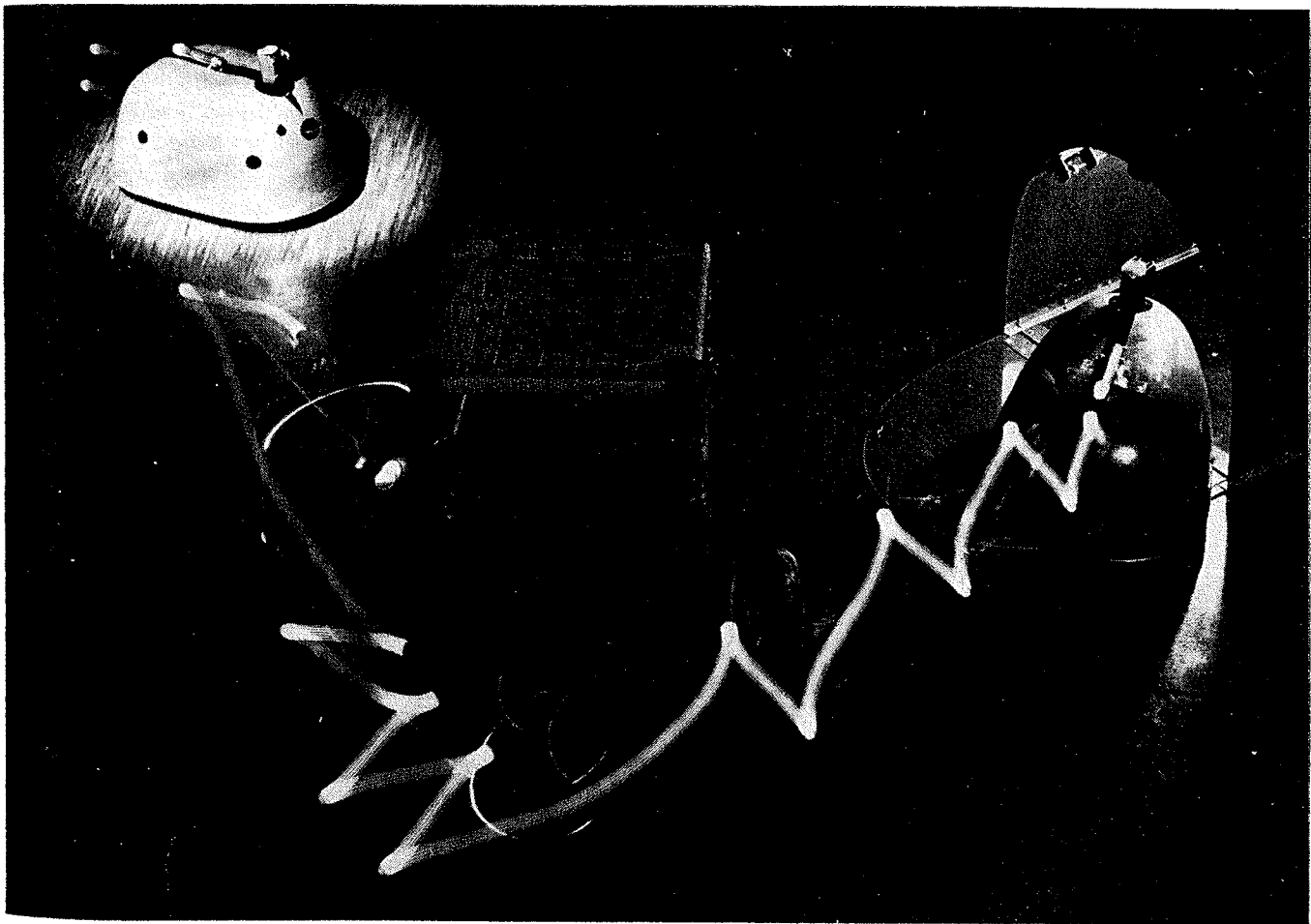

MACHINA SPECULATRIX, photographed by time exposure, is attracted by light in hutch at right. It begins

at left, encounters obstacle, backs away, encounters obstacle again, backs away again and enters the hutch.

essential only that the energy should be in such a form that it can be readily available for the final operation.

7. This final phase is the combination of the preserved trace with a fresh S_n to give E_s as the new conditioned response. The operation is analogous to the testing by experiment of a hypothesis, the hypothesis here being the likelihood of a correlation between S_s and S_n .

In terms of conditioned reflexes, the acquired response must be reinforced, otherwise it will vanish without trace. Consequently when the fresh S_n is presented in the seventh operation, it must be followed by the confirming S_s . Eventually, after a number of such events, the new response $S_n \rightarrow E_s$ is permanently established and requires no further corroboration.

ALL THIS can be represented in a diagram of a simple nervous system (see the lower of the two diagrams at the lower left-hand side of this page). In this drawing there are two series of nerve cells—two reflex arcs—which correspond to the transmission systems T_1 and T_2 . Between the two is a network of nerve cells which serve to perform the seven operations detailed above. Branching off from the first reflex arc is a synapse (1) with the property of discharging only at the beginning of the stimulus; this corresponds to the perception of food. In the second reflex arc is a synapse (2) with a long after-discharge: the prolongation of the neutral stimulus. The signals from the two stimuli both reach a neurone at (3), are mixed there and added together at (4).

When the summated inputs reach a certain level, they discharge a trigger neurone (5). This introduces a pulse into the quiescent closed circuit at (6) which, by reason of positive feedback, continues to oscillate for a long while. An output from this leads to a mixing neurone at (7), which is also connected directly with the second reflex arc. This neurone can only discharge when it is activated simultaneously by signals from the storage circuit at (6) and a signal from the second reflex arc. When it does receive signals from both, its discharge is conducted to the output of the first reflex and has the specific effect E_s . It thus acts as a gate to E_s —normally shut to S_n but opened by the memory that S_n has often been followed by S_s .

Once this scheme had been worked out, it became possible to create an electronic circuit to perform the necessary operations (see diagram at the lower right-hand side of these two pages). The details are perhaps of interest only to an electrical engineer; the system involves a number of electronic tubes coupled with capacitors, resistors and so on in such a way that the signals are properly amplified, timed and mixed, and the resulting pulses are combined to produce the desired results.

In one arrangement of the working model of *M. docilis* the specific stimulus is a moderate light and the neutral one is the sound of a whistle. The whistle is blown just before the light is seen; after this has been repeated 10 or 20 times the model has "learned" that the sound means light and will come to the whistle as though it were a light. If it is teased

by withholding of the light, it soon forgets the lesson and disregards the sound. In another arrangement the specific stimulus is touch, that is, an encounter with an obstacle. In that case the whistle is blown just as the model comes into contact with the obstacle, so that after a while the warning whistle triggers a withdrawal and avoidance reaction. This process may of course be accelerated by formal education: instead of waiting for the creature to hit a natural obstacle the experimenter can blow the whistle and kick the model. After a dozen kicks the model will know that a whistle means trouble, and it can thus be guided away from danger by its master. This last is an example of a negative or defensive conditioned reflex; as in an animal, responses of this type are more easily established and retained than any other. Because the mechanism sets up very large oscillating pulses which keep feeding into the learning circuit, the conditioned reflex, once established, lasts as long as the decay time of the memory and requires little or no reinforcement.

SEVERAL interesting problems arose in the working out of these experiments. For example, the use of sound as a conditioned stimulus was convenient, but the internal noise of the motors and gears was so loud compared with an external sound that the model could not "hear" the signal. It was found necessary to provide a special amplifier with a resistance-capacitance feedback circuit sharply tuned to the note of a whistle—about 3,000 cycles per second. As an alternative we tried arranging a muting

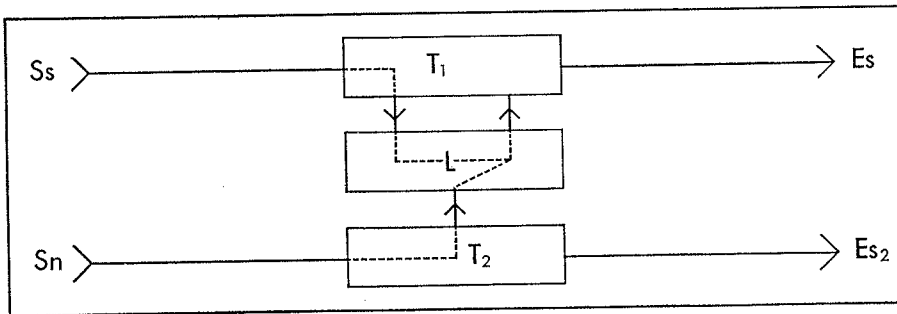

LEARNING links two systems. S_s and S_n are specific and neutral stimuli; E_s and E_{s_2} , effects; T_1 and T_2 , transmission systems; L , learning box.

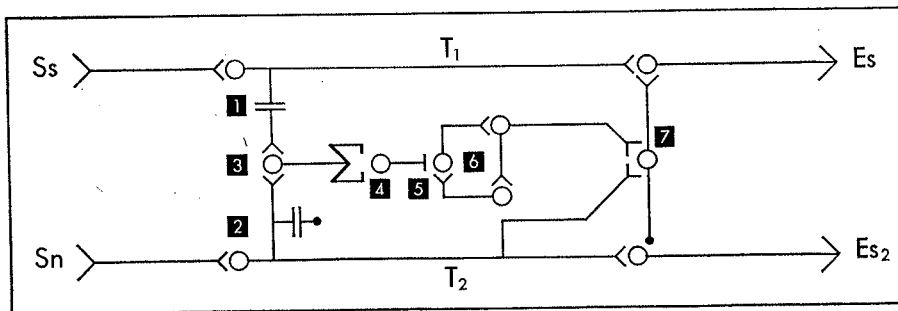

CONDITIONED REFLEX requires this arrangement of nerve cells. Numbers correspond to operations described in text and to diagram at right.

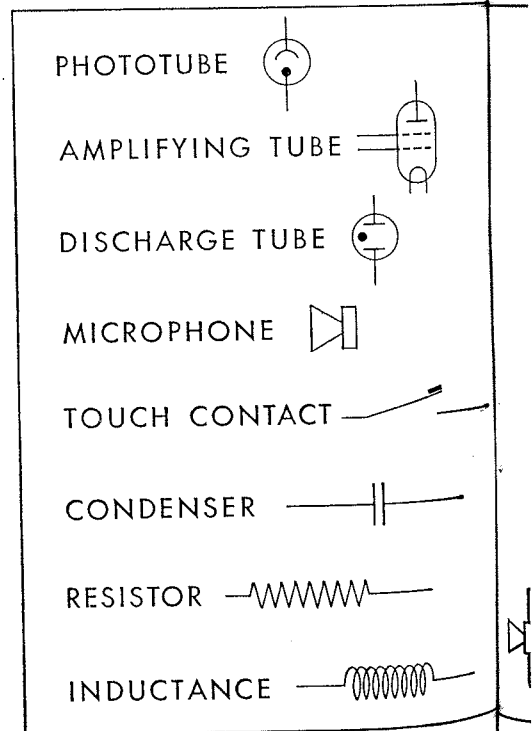

CIRCUIT for Cora, which stands for conditioned reflex analogue, is out-

mechanism whereby the motors were turned off periodically and the microphone was simultaneously switched on for a moment to pick up any extraneous sound. This type of gating mechanism emphasizes the importance of the stretching operation applied to the sound signal, for the information the latter conveys is used after the brief listening period, which may occur only once a second for a tenth of a second. The muting-pulse device was not adopted because it seemed more complicated than the sharply tuned amplifier, but the former may be more akin to the physiological mechanisms in living creatures.

Further complications in *M. docilis* arise when the sound amplifier (neutral stimulus) is arranged to produce its own specific effect. For example, it can easily be arranged to make the sound switch off all motors, so that the model "freezes" when it hears the whistle. Such a reaction is very common in animals; many marsupials and rodents "play possum" when they hear a strange noise. If now it is intended to teach the model that sound means light, which may mean food, the freezing reaction must be inhibited to permit conditioning of the new response. A separate branch must therefore be taken from the output of the mixing tube at (7) to the output of the sound amplifier, whereby the "instinctive" effect of the latter is suppressed as soon as the positive conditioning has been established.

WE have described so far the simplest possible mechanism, consisting only of a single learning circuit connected to

two signal amplifiers. With this arrangement the model is reasonably docile. But if we introduce a second learning circuit, or build in two neutral or specific signals instead of one, it becomes only too easy to establish an experimental neurosis. Thus if the arrangement is such that the sound becomes positively associated both with the attracting light and with the withdrawal from an obstacle, it is possible for both a light and a sound to set up a paradoxical withdrawal. The "instinctive" attraction to a light is abolished and the model can no longer approach its source of nourishment. This state seems remarkably similar to the neurotic behavior produced in human beings by exposure to conflicting influences or inconsistent education. In the model such ineffective and even destructive conditions can be terminated by rest, by switching off or by disconnecting one of the circuits. These treatments seem analogous to the therapeutic devices of the psychiatrist—sleep, shock and psychosurgery.

In *M. docilis* the memory of association is formed by electric oscillations in a feedback circuit. The decay of these oscillations is analogous to forgetting; their evocation, to recall. If several learning pathways are introduced, the creature's oscillatory memory becomes endowed with a very valuable feature: the frequency of each oscillation, or memory, is its identity tag. A latent memory can be detected and identified among others by a process of frequency analysis, and a complex of memories can be represented as a synthesis of oscillations which yields a characteristic wave pattern. Further-

more a "memory" can be evoked by an internal signal at the correct frequency, which resonates with the desired oscillation. The implications of these effects are of considerable interest to those who study the brain, for rhythmic electrical oscillation is the prime feature of brain activity. We may gain new respect for the speculations of the English physician-philosopher David Hartley, who 200 years ago suggested that ideas were represented in the brain as vibrations and "vibratiuncles."

THESE models are of course so simple that any more detailed comparison between them and living creatures would be purely conjectural. Experiments with larger numbers of circuits are perfectly feasible and will certainly be instructive. One weakness of more elaborate systems can be predicted with confidence: extreme plasticity cannot be gained without some loss of stability. In the real world an animal must be prepared to associate almost any event with almost any other; this means that if a nervous system contains N specific receptor-effector pathways, it should also include something of the order of N^2-N learning circuits. In such a system the chances of stability decline rapidly as N increases. It is therefore no wonder that the incidence of neuropsychiatric complaints marches with intellectual attainment and social complexity.

W. Grey Walter is director of the physiological department at the Burden Neurological Institute in Bristol, England.

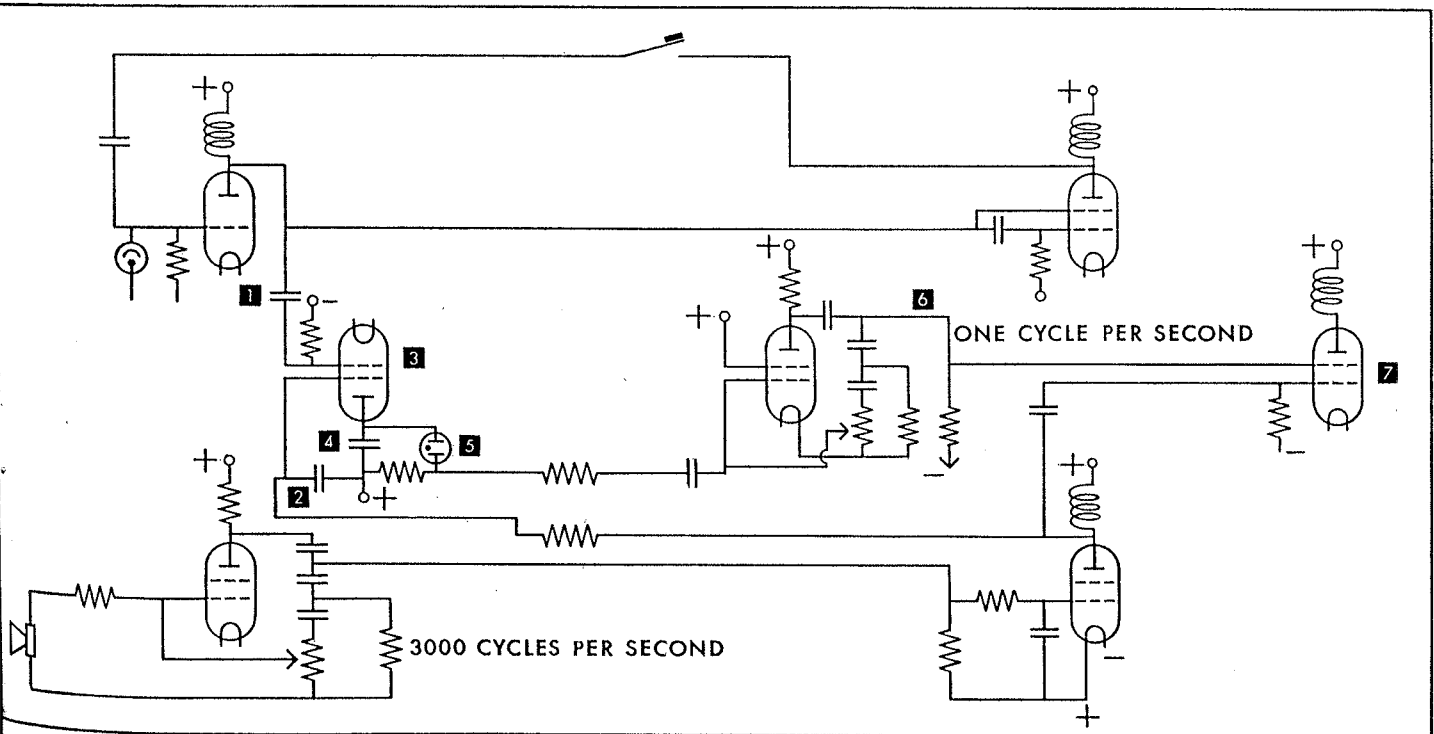

lined by simplified diagram. The circuit element labeled "3,000 cycles per second" is tuned so that Cora responds

only to sound of that frequency. The element labeled "one cycle per second" provides machine with memory.